

StarCam controller board connections

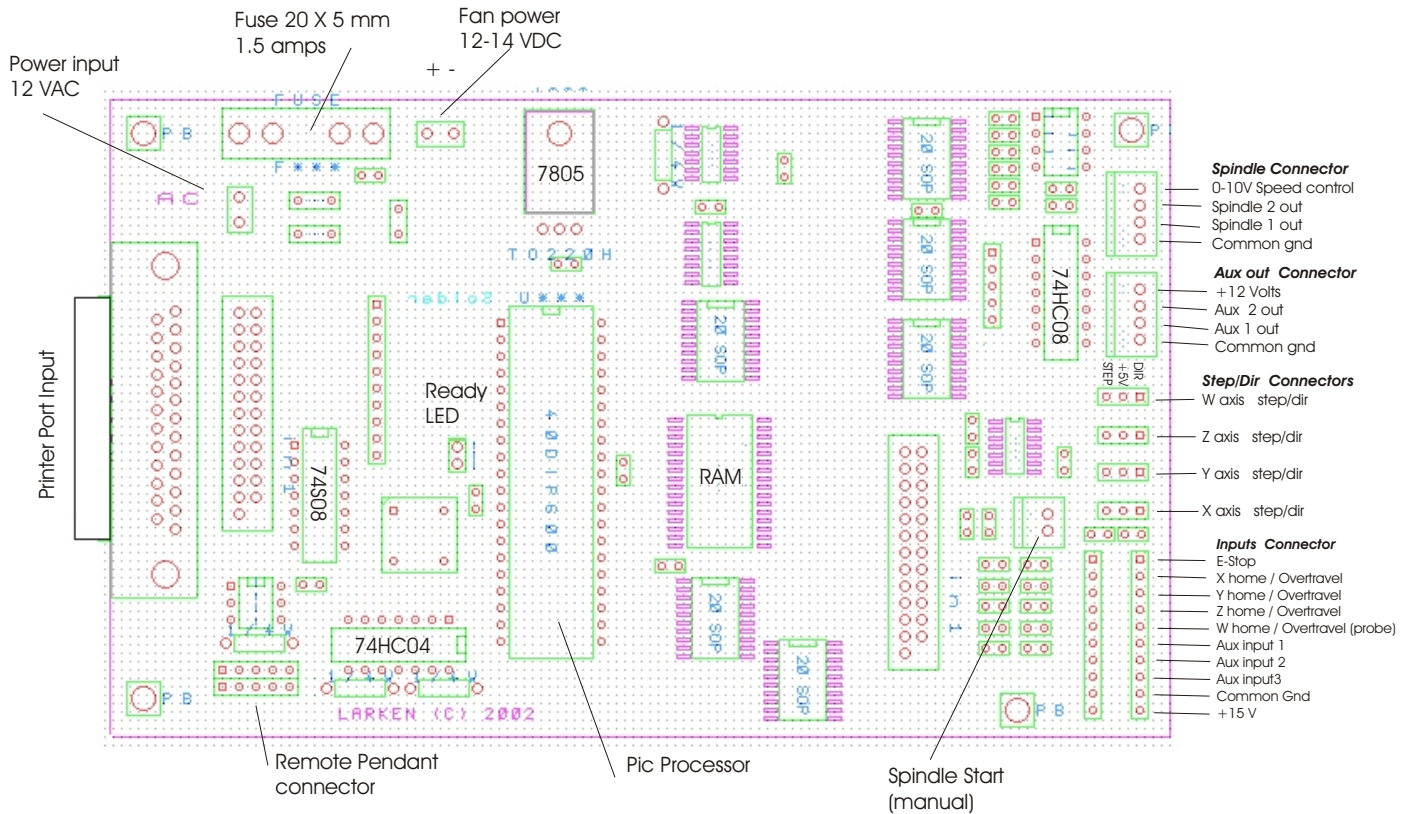

NOTES

- This controller board must be properly mounted in a metal case with the 25 pin input connector secured to a grounded chassis panel, otherwise electrical interference may result causing data errors
- Keep motor driver output wires at least 3" from this board as they generate RFI
- Power should be supplied by a 10-12vac transformer
- A connector is supplied to power a compact 12Vdc fan with a max current of 200ma
- Spindle and Aux outputs are 0V OFF and +5Vdc ON. If the 74HC08 output chip is replaced by a 74LS38, then these outputs will be open-collector
- Note some controller boards were shipped with a 74F08 instead of a 74S08 (the chip near the 25 pin connector). The 74F08 can cause data errors. Call Larken and we will send a free 74S08.

Connecting Limit switches to the Larken Interface board

Using Micro Switches for home/overtravel switch

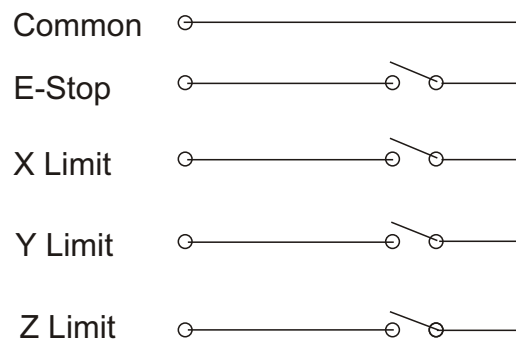

Using an Opto Switch for home/overtravel switch

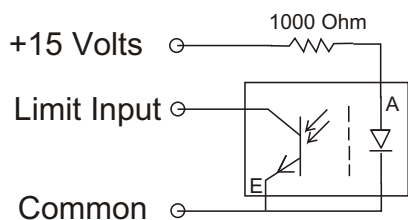

Opto Interrupter
Module



Vane can be mounted
on each end of Axis

Digi-key PN / H21B1QT-ND
(Darlington output)

Note : The 'Limit SW polarity' setting should be set to 1 for Normally Closed

Adding components for the 0-10 Volt speed control

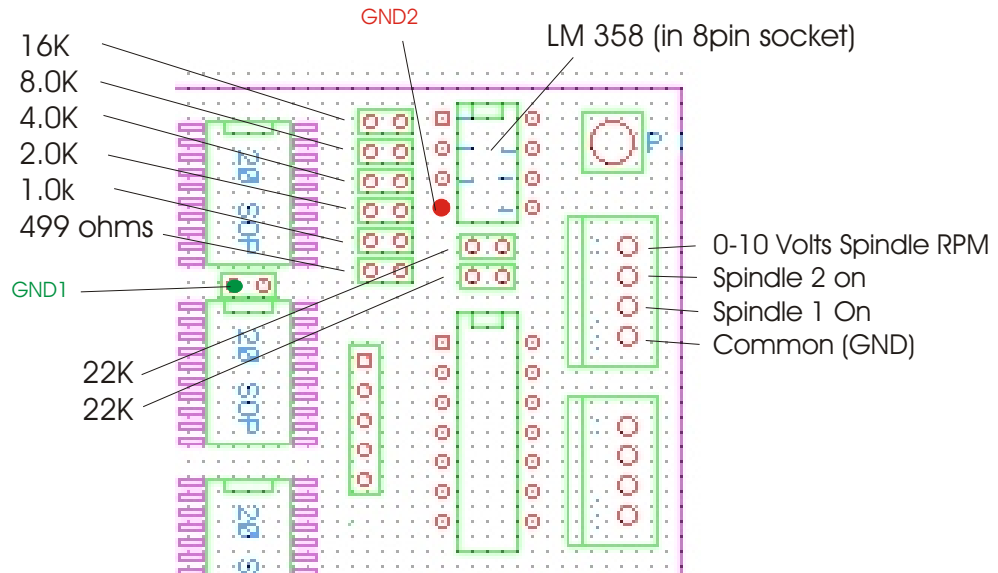

Notes

(This analog 0-10Volt feature only works on Controller boards manufactured after June 2005. Previous Larken Starcam boards will not work.)

- Install 8 pin socket for Lm358 IC
- Use 1% resistors for most accuracy
- Fix error on PCB. Connect a short wire between GND1 and GND2 on back side of board (Gnd1 is located on .1uF Cap and GND2 is pin 4 on LM358)
(This repairs a missing ground connection)
- Program your Spindles Inverter drive for minimum RPM at 0V and Maxrpm at 10V.